

JOSEPH P JENSEN

**Bluetooth Low Energy from the
Airline's point of view- a case study
in how to solve ULD challenges**



AGENDA

- ✓ Behind the Curtain- Delta ULD Control
- ✓ Promo Video
- ✓ The ULD Agency Dilemma
- ✓ How do we permanently solve our issues?
- ✓ Bluetooth Low Energy as an Operator
- ✓ Closing/Questions

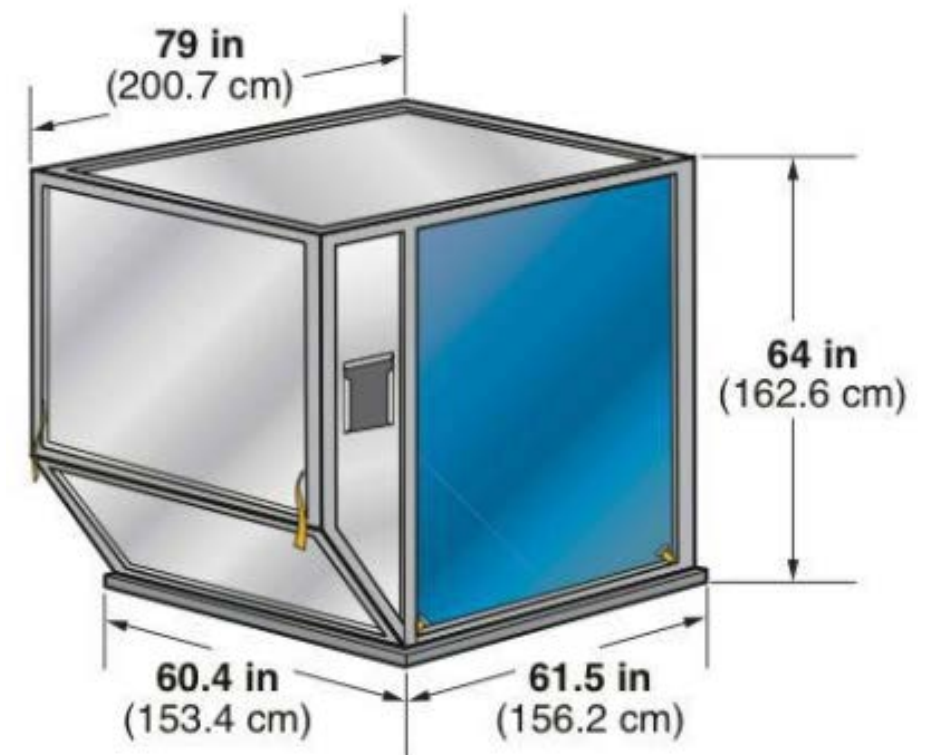

PROMO VIDEO

[Delta Technology Video](#)

BEHIND THE CURTAIN- DELTA ULD CONTROL

*Team Responsibilities

- ULD Serviceability
- DCOM Chapter 40
- SPPM 67
- Station Allocations
- Luggage Logistics
- BLE Program
- Demurrage
- Pharma Tracking
- FAA Compliance
- Purchase Plans
- Imbalances & Modeling
- Restraint Devices
- SAE 2A / IATA ULD-B
- JV ULD
- CCC
- Leasing



International Repair Vendors

- NRT- ACL Airshop
- HKG- GSEL
- AMS- ACL Airshop
- LHR- Modulus
- ICN- Proposed 2019
- PVG/PEK- Proposed 2019
- TLV- Under Review



THE ULD AGENCY DILEMMA

The **agency** problem is a conflict of interest inherent in any relationship where one party is expected to act in another's best interests

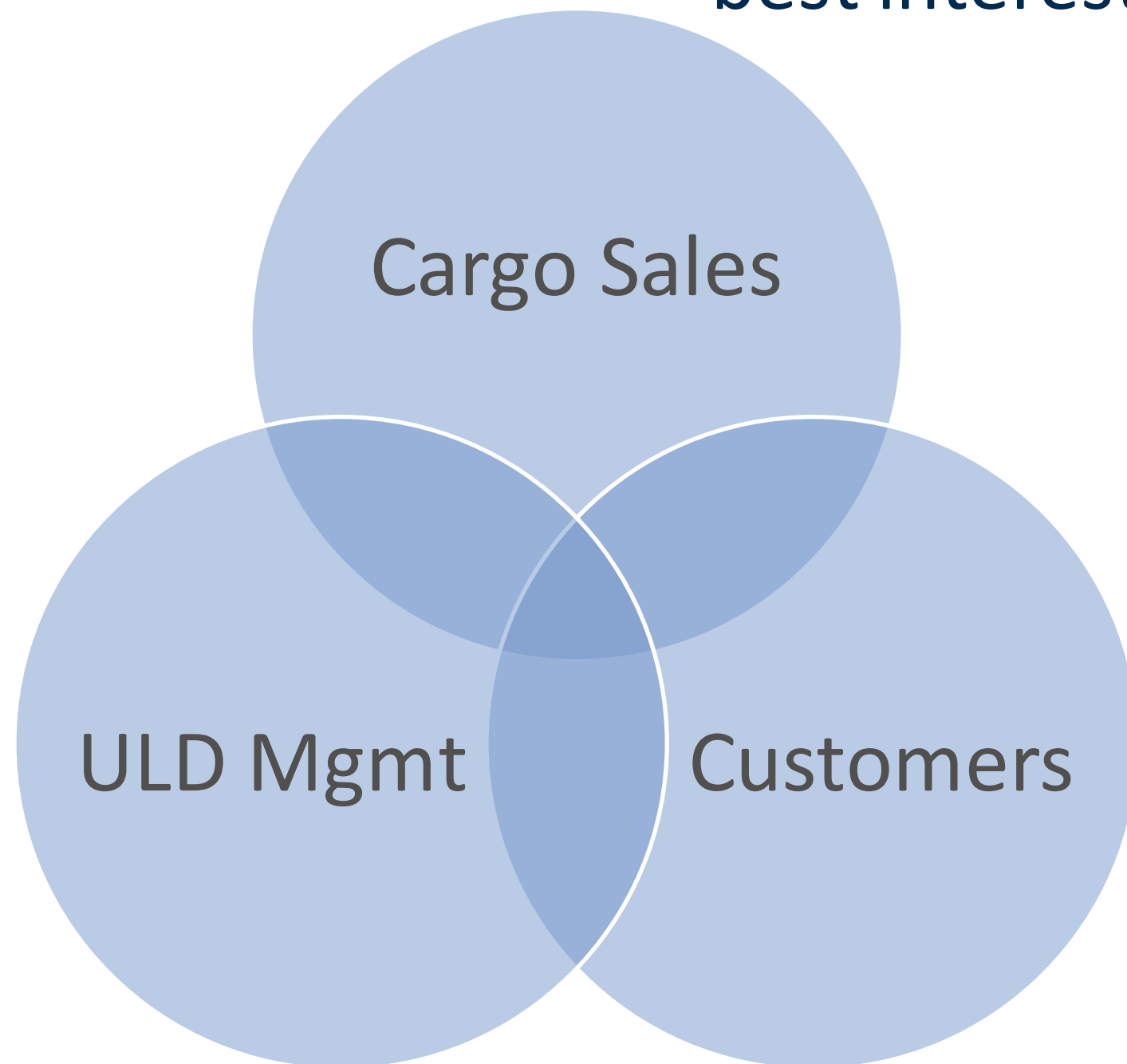

ULD Examples

- ✓ Demurrage vs Customers
- ✓ Overbooking vs Supply
- ✓ Revenue vs Cost
- ✓ Alliances vs Fleet
- ✓ ULD Mgmt vs Ops
- ✓ New ULDs vs Finance

HOW DO WE SOLVE FOR THESE ISSUES?

- ✓ Align goals amongst all 3 circles
- ✓ Universal acceptance of the virtuous circle
 - Support your foundational processes (ULD)
 - Decrease operational failures
 - Trust in your people
 - Increase customer satisfaction
 - Customers drive more business
 - Revenues increase
 - Reinvest in the foundational processes
- ✓ Technology alone will not solve your challenges-
only great leadership and employees can



BLE AS THE AIRLINE OPERATOR

Bluetooth low energy tracking supports the virtuous circle and solves the agency dilemma

BLE benefits all 3 groups- (a few examples)

Cargo Sales	Customers	ULD Management
Tracking as a cargo service offering	Comfort & Piece of mind	Find lost & missing ULDs
Better ULD inventory availability	Eliminates manual processes	More efficient inventory
Pre-alert customers of delayed shipments	Transparent data & push notifications	Big Data / Reduce cost

WHERE ARE WE TODAY?

85 cargo warehouses & 8,000 + units tagged

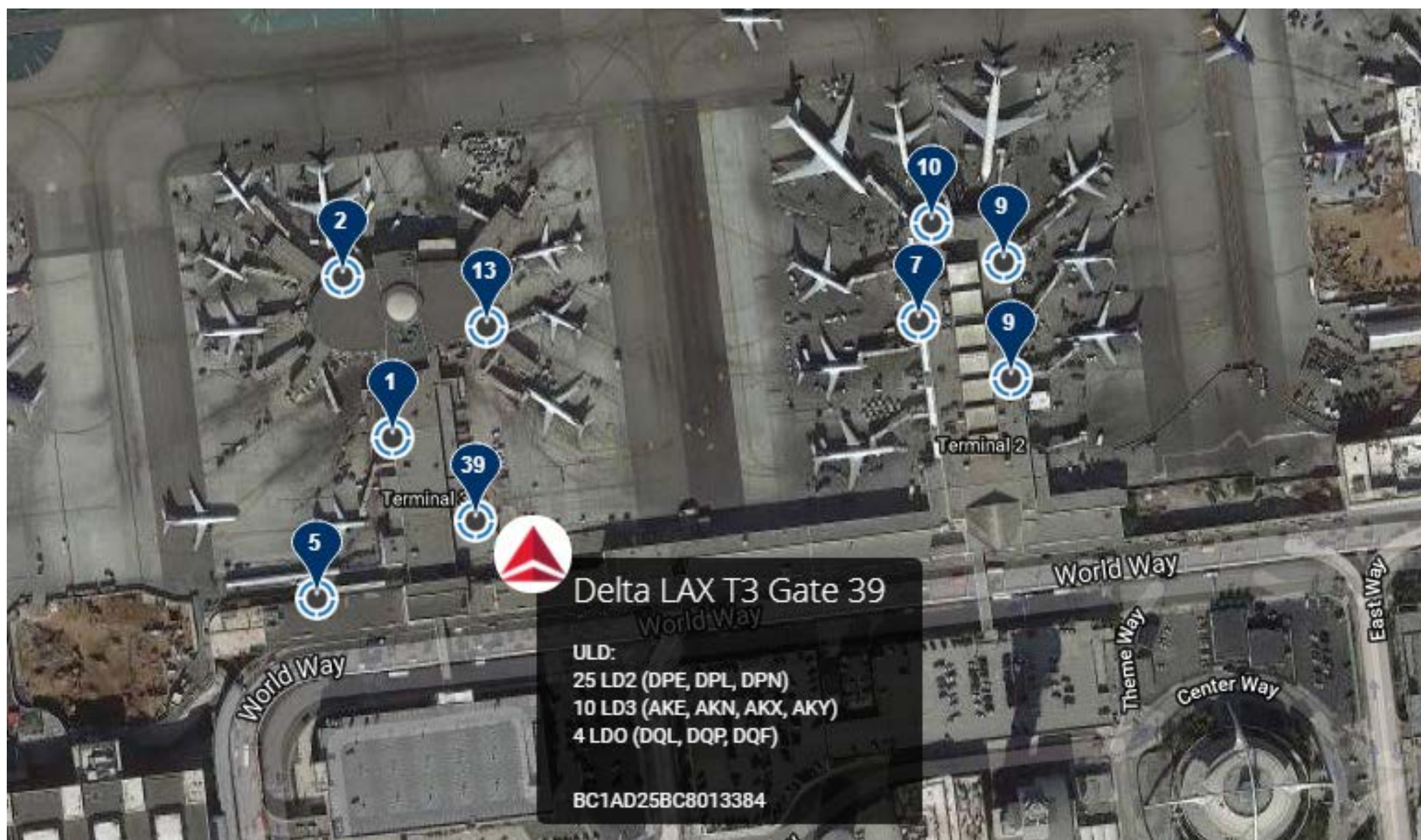

CONCLUSIONS & QUESTIONS



- ✓ High-Speed Bluetooth Roll-Out is Happening at Delta
- ✓ Will Yield Better Logistics Efficiencies for our Shipper Clients
- ✓ Linked with Our New Cargo Ops Center
- ✓ A Whole New Competitive Advantage